

Use this diagram for vehicles with combined brake & turn signal bulbs:

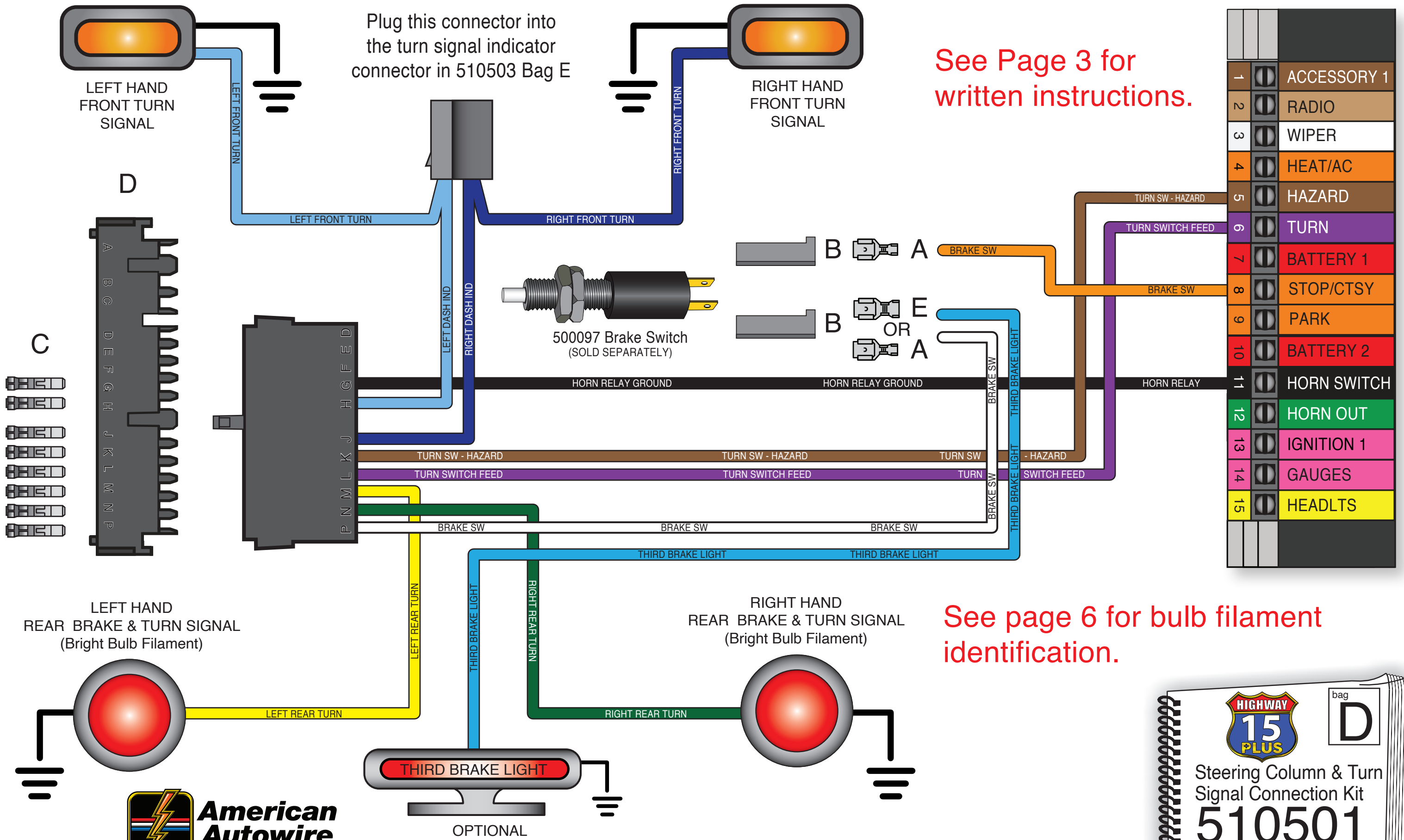

See Page 3 for written instructions.

1	ACCESSORY 1
2	RADIO
3	WIPER
4	HEAT/AC
5	HAZARD
6	TURN
7	BATTERY 1
8	STOP/CTSY
9	PARK
10	BATTERY 2
11	HORN SWITCH
12	HORN OUT
13	IGNITION 1
14	GAUGES
15	HEADLTS

See page 6 for bulb filament identification.



Use this diagram for vehicles with the brake & rear turn signals on separate bulbs:

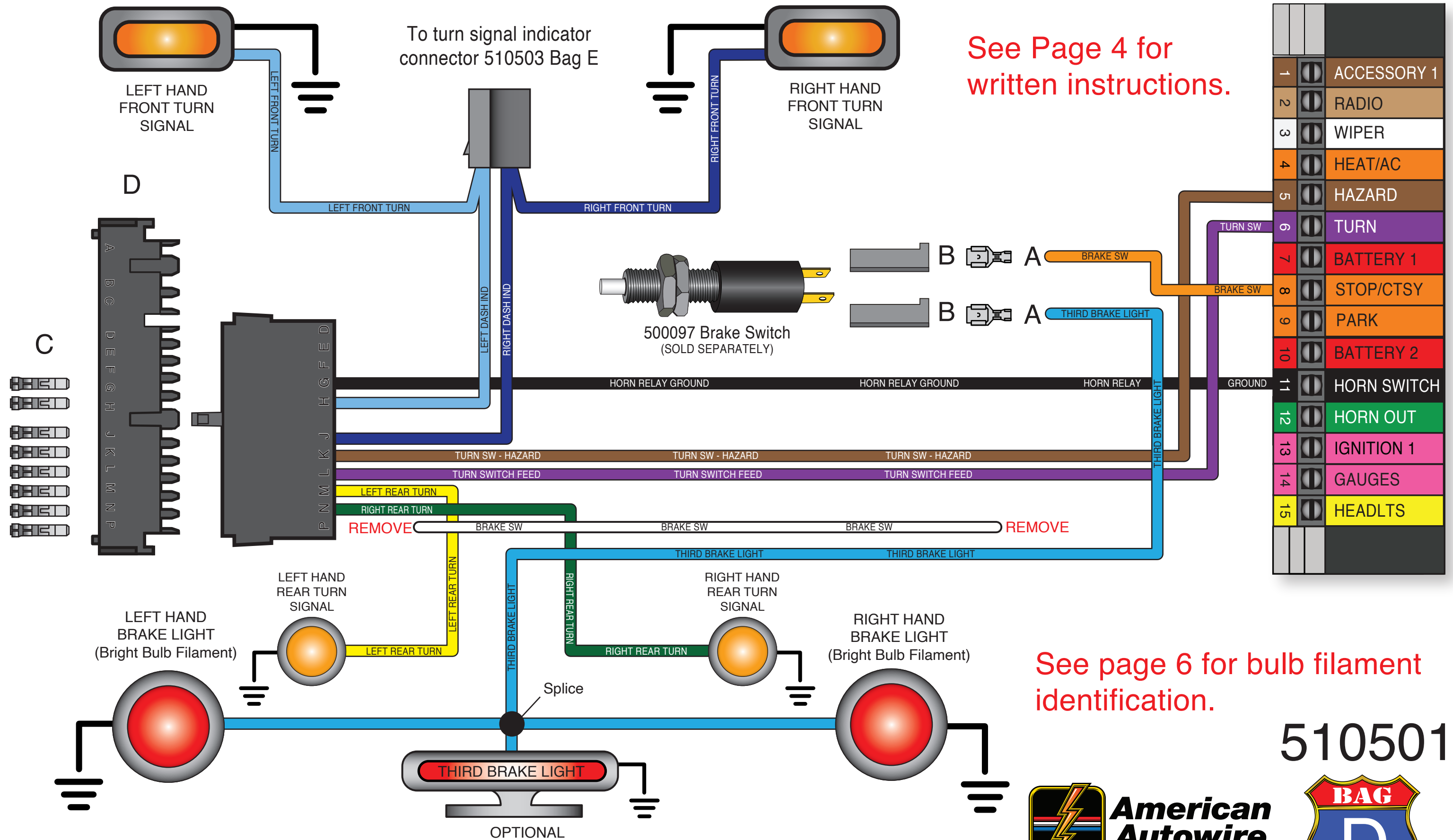

INSTALLATION INSTRUCTIONS: This sheet will cover vehicles that are using a shared brake light and rear turn signal

This kit has a GM steering column connector supplied on the wires. This connector will plug into most GM columns for 1969-1976 (along with some aftermarket columns) If your existing column connector does not match the connector on this kit, install the mating connector "D" and terminals "C" which are supplied, as shown on page 1.



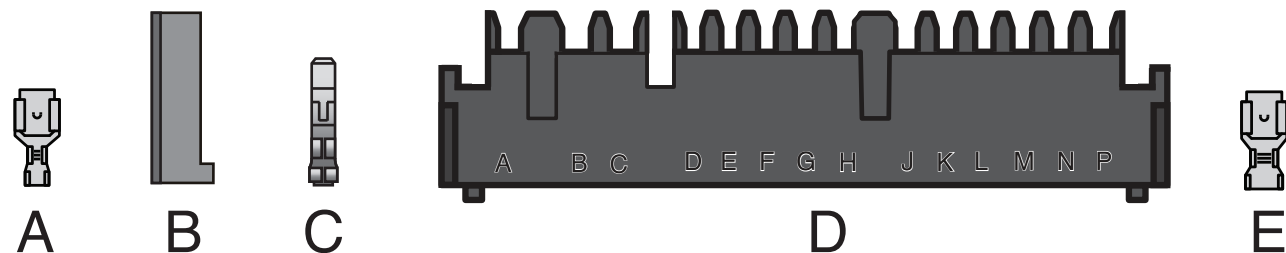









WIRE COLOR	CIRCUIT	INSTALLATION
YELLOW	LEFT REAR TURN	Route and connect the yellow wire to your left tail light (stop, and turn location)
DK GREEN	RIGHT REAR TURN	Route and connect the dark green wire to your right tail light (stop, and turn location)
LT BLUE	LEFT FRONT TURN	Route and connect the light blue wire to the left front turn signal lamp (turn location)
DK BLUE	RIGHT FRONT TURN	Route and connect the dark blue wire to the right front turn signal lamp (turn location)
ORANGE	BRAKE SWITCH FEED	Crimp the single female terminal "A" and plug into connector "B". Plug this connection into the brake switch. Route the other end of the orange wire to the panel, cut to length, and insert it into the "STOP/CTSY" location on the panel.
ORANGE	DOME/COURTESY LIGHT FEED	Connect one end to the panel "STOP/CTSY" location, route the other end to the dome/ctsy lamps. The ground side of the csty/dome lamp circuit is connected to the white wire from the headlight switch, and the door jamb switch.
WHITE	BRAKE SWITCH OUTPUT	Route this wire to the brake switch and cut to length. If you are using a third brake light, do not terminate yet (see LT BLUE wire below). If you are not using a third brake light, use the supplied terminal "A" and connector "B", and plug into your brake switch.
LT BLUE	THIRD BRAKE LIGHT	If you are not using a third brake light, ignore the installation of thlight blue wire. Otherwise, connect this wire to the WHITE "Brake switch feed out" wire above using the supplied terminal "E" and connector "B" and plug into the brake switch. Route the other end of LT BLUE wire to the third brake light.
BLACK	HORN RELAY GROUND	Route the black wire to the panel and insert it into the "HORN SW" location on panel.
PURPLE	TURN SWITCH FEED	Route the purple to the panel and insert it into the "TURN SW" location on panel.
BROWN	TURN SWITCH HAZARD	Route the brown to the panel and insert it into the "HAZARD" location on panel.
LT BLUE DK BLUE	TURN SIGNAL INDICATOR	Plug this connector into the 2 position connector in the 510503 kit.



HIGHWAY 15 PLUS

INSTALLATION INSTRUCTIONS: This sheet will cover vehicles that are using a separate brake light and rear turn signal

This kit has a GM steering column connector supplied on the wires. This connector will plug into most GM columns for 1969-1976 (along with some aftermarket columns) If your existing column connector does not match the connector on this kit, install the mating connector "D" and terminals "C" which are supplied, as shown on page 1.

WIRE COLOR	CIRCUIT	INSTALLATION
	LEFT REAR TURN	Route and connect the yellow wire to the left rear turn signal (turn location)
	RIGHT REAR TURN	Route and connect the dark green wire to the right rear turn signal (turn location)
	LEFT FRONT TURN	Route and connect the light blue wire to the left front turn signal lamp (turn location)
	RIGHT FRONT TURN	Route and connect the dark blue wire to the right front turn signal lamp (turn location)
	BRAKE SWITCH FEED	Crimp the single female terminal "A" and plug into connector "B". Plug this connection into the brake switch. Route the other end of this wire to the panel, cut to length, and insert it into the "STOP/CTSY" location on the panel.
	DOME/COURTESY LIGHT FEED	Connect one end to the panel "STOP/CTSY" location, route the other end to the dome/ctsy lamps. The ground side of the csty/dome lamp circuit is connected to the white wire from the headlight switch, and the door jamb switch.
	BRAKE SWITCH OUTPUT	Do not connect this wire if using separate rear turn signals and brake lights. See example on page 3
	THIRD BRAKE LIGHT	Crimp the single female terminal "A" and plug into connector "B". Plug this connection into the brake switch. Route the other end of LT BLUE wire to the brake light bulb (bright filament).
	HORN RELAY GROUND	Route the black wire to the panel and insert it into the "HORN SW" location on panel.
	TURN SWITCH FEED	Route the purple wire to the panel and insert it into the "TURN SW" location on panel.
	TURN SWITCH HAZARD	Route the brown wire to the panel and insert it into the "HAZARD" location on panel.
	TURN SIGNAL INDICATOR	Plug this connection into the 2 position connector in the 510503 kit.

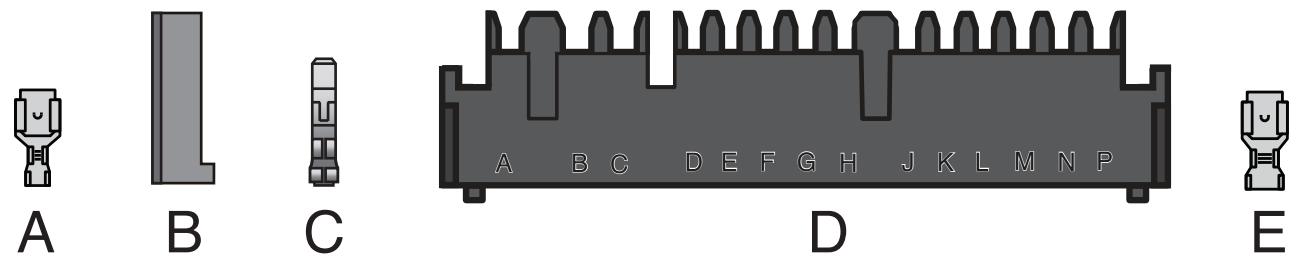

HIGHWAY 15 PLUS

Two wire dome lamp with headlight and door jamb switch activation using 500081 courtesy light kit

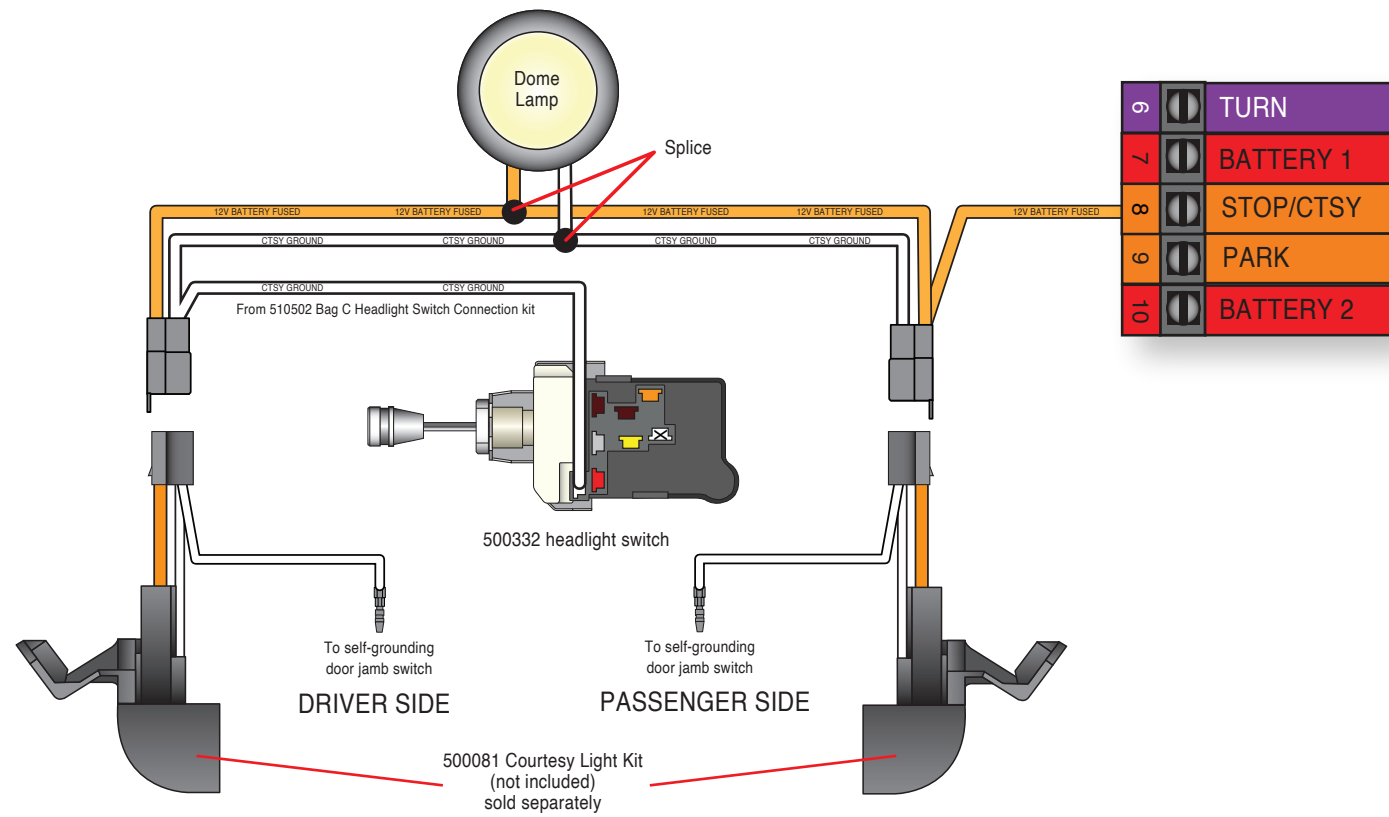

Two wire dome lamp with headlight and door jamb switch activation

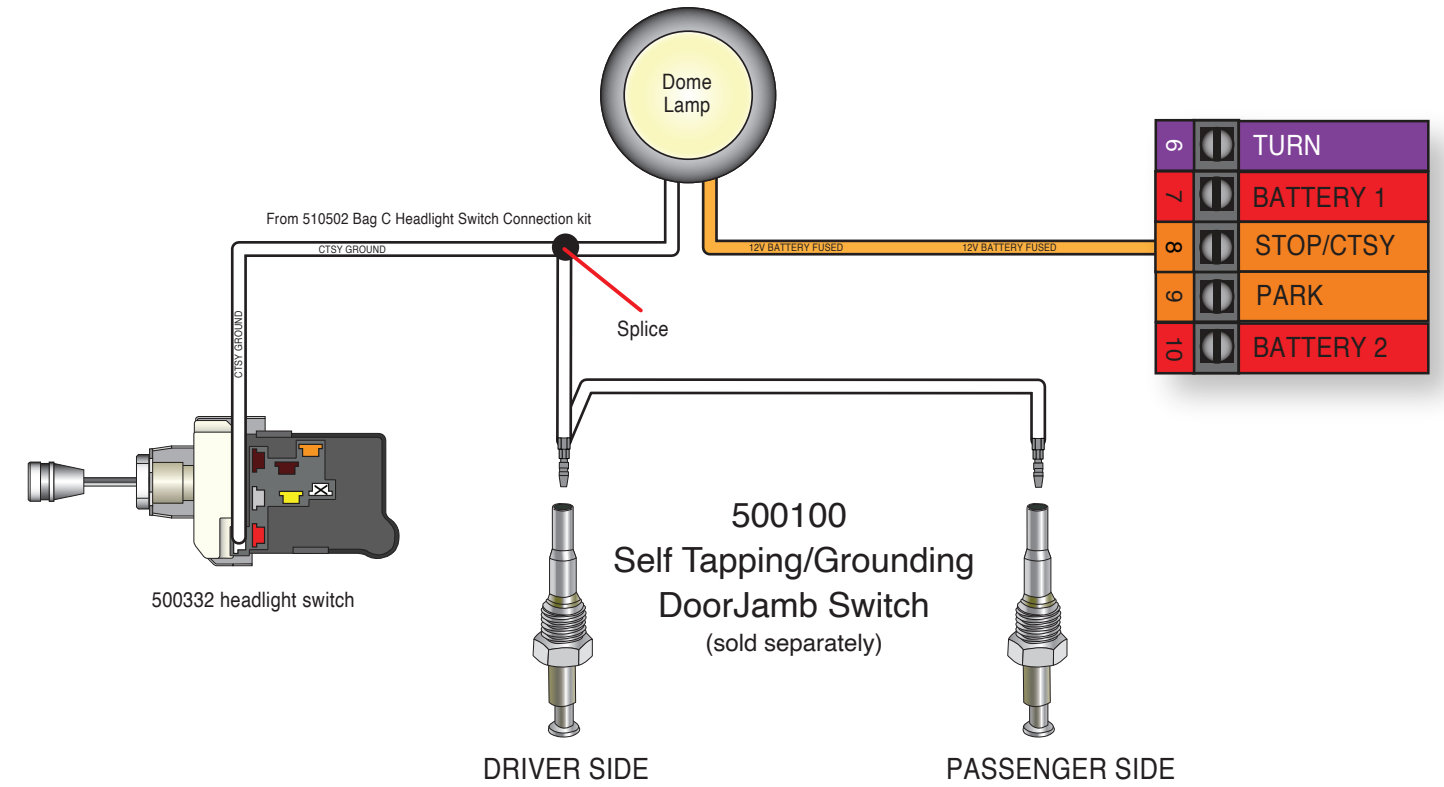

Self-grounding dome lamp with On/Off switch with door jamb switches that switch power

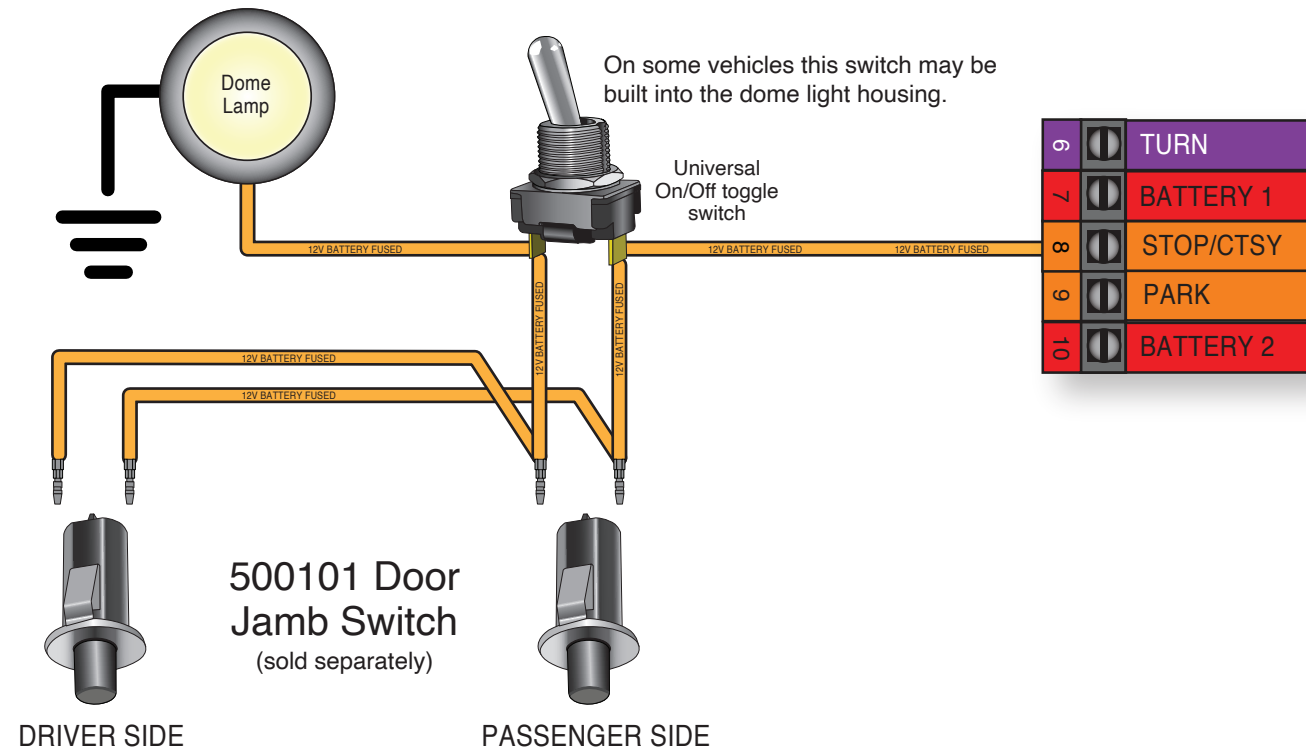

Two wire dome lamp with headlight switch activation

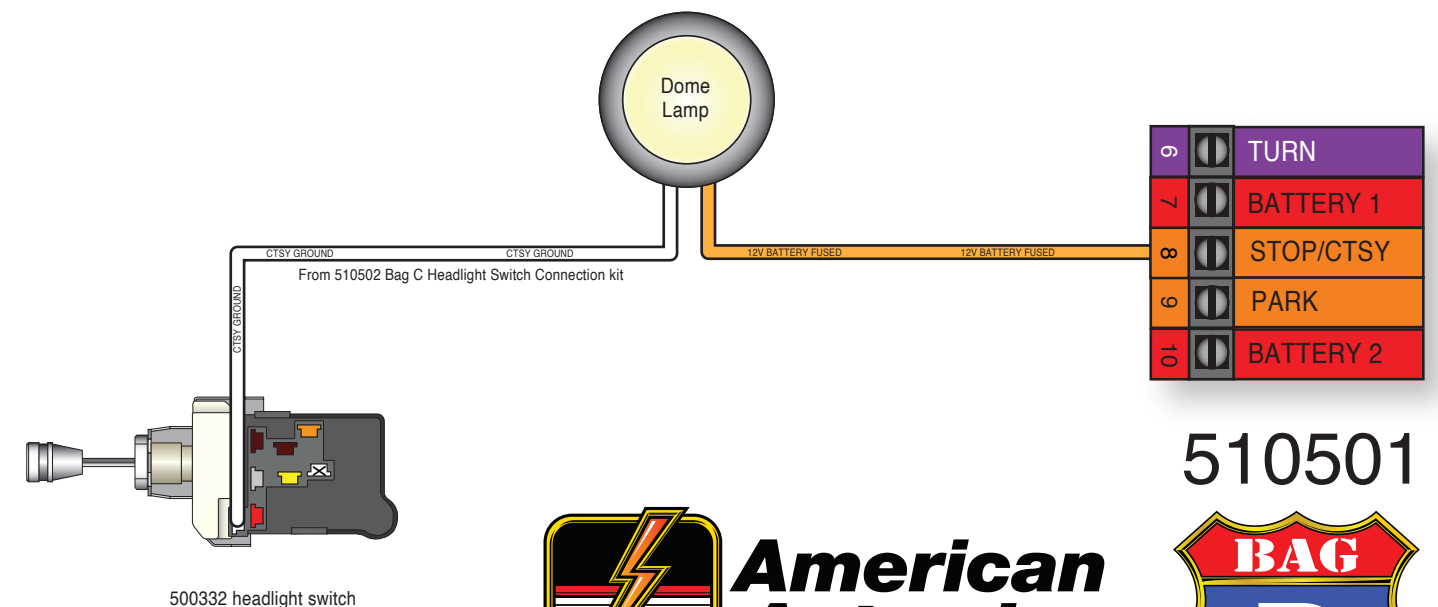

**American
Autowire**

www.americanautowire.com 856-933-0801

510501



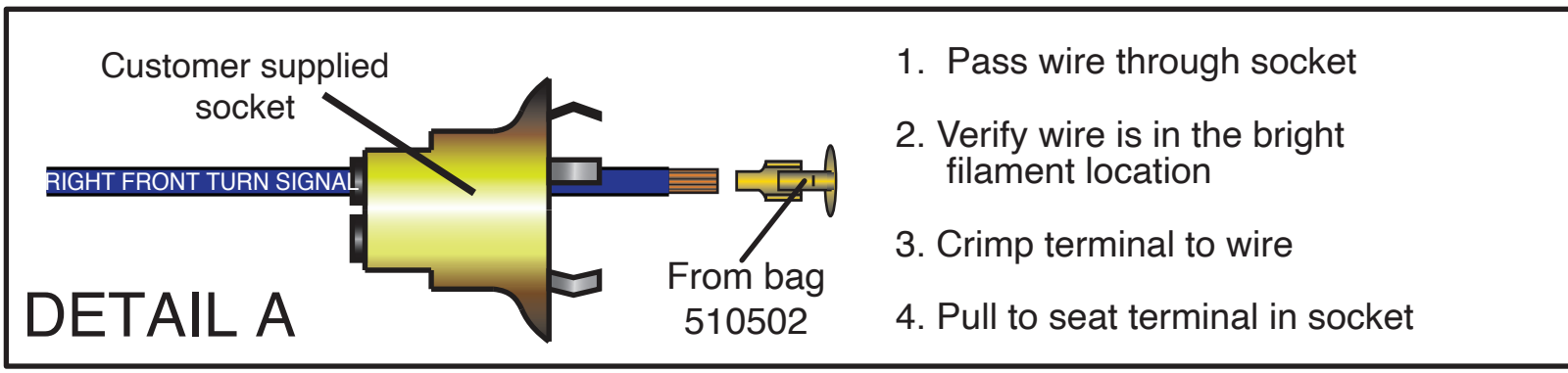

1. Pass wire through socket
2. Verify wire is in the bright filament location
3. Crimp terminal to wire
4. Pull to seat terminal in socket

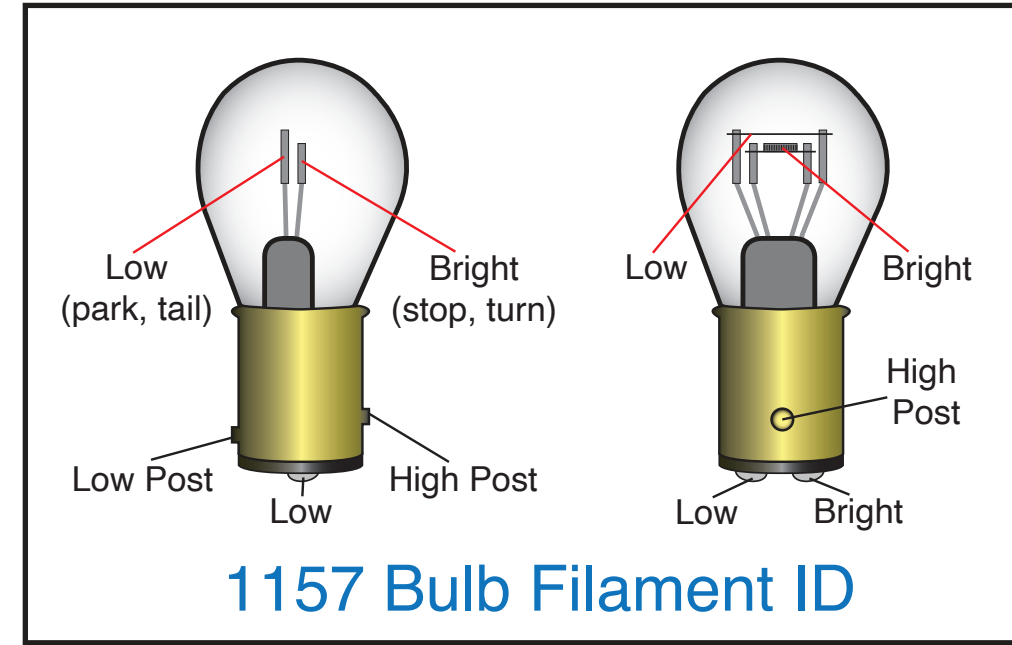

Suggested items:

510643 Terminal Kit

We've included the most common terminals and connectors that will help you with troubleshooting, repairing, or replacing connections. All contents are compartmentalized in a durable case with a heavy duty latching closure. The inside of the lid has a diagram detailing the contents by image and description.

500097 - Brake Switch

Pedal mounted brake switch. Universal fit. Comes complete with connectors and terminals. Many different styles available in our catalog.

500081- Courtesy Kit

For connecting two under dash lamps to headlight switch & door switches. Has sockets w/ mounting brackets & terminals for bullet, blade, or screw type door switches.

510587 - Wire Crimpers

The single crimper is used for wire sizes ranging from 14 to 20 gauge, and the double crimper is used for sizes from 10 to 18 gauge, or terminals receiving a two wire connection.

500350 - 12"
500656 - 18"
Ground Straps

Medium duty ground straps are 100% tinned copper. Both sizes have a 3/8" hole on both ends.

HIGHWAY 15 PLUS

510501



www.americanautowire.com 856-933-0801